

2. GENERAL REGULATIONS

2.4 PAYMENT ARRANGEMENTS AND CREDIT ALLOWANCES (CONT'D)

2.4.7 ORDERING, RATING AND BILLING OF ACCESS SERVICES WHERE MORE THAN ONE EXCHANGE TELEPHONE COMPANY IS INVOLVED

The Multiple Exchange Carriers Access Billing Guidelines (MECAB) and the Multiple Exchange Carriers Ordering and Design Guidelines (MECOD) are the standards on which the regulations in the following paragraphs are based. These standards determine the ordering, rating and billing for Access Services when the service is provided by more than one Exchange Telephone Company.

All information necessary for billing, ordering and design coordination will be provided based on the standards in the MECAB and MECOD guidelines to ensure that jointly provided Access Services are installed, tested and turned up in a timely manner.

A. Feature Group A Switched Access Service

1. The ordering, rating and billing of Feature Group A Switched Access Service will be based on revenue-sharing agreements between the Exchange Carriers jointly providing the service.
2. For Feature Group A Switched Access Service, the Exchange Telephone Company in whose territory the first point of switching is located will accept the order. In addition, the Exchange Telephone Company in whose territory the customer's POT is located must also receive a copy of the order from the customer.
3. The Exchange Telephone Company that accepts the order will then determine the charges involved, arrange to provide the Access Service ordered and bill the charges in accordance with its Access Service Tariff.

2. GENERAL REGULATIONS

2.4 PAYMENT ARRANGEMENTS AND CREDIT ALLOWANCES

2.4.7 ORDERING, RATING AND BILLING OF ACCESS SERVICES WHERE MORE THAN ONE EXCHANGE TELEPHONE COMPANY IS INVOLVED (CONT'D)

B. Feature Groups B, C and D Switched Access Service and Directory Assistance Access Service

When more than one Exchange Telephone Company is involved in the provision of Access Service, the customer requesting initial service will be notified in writing at least thirty (30) days prior to the initial billing date which Exchange Telephone Company's set of terms and conditions apply and of the billing arrangement for any jointly provided Access Service ordered. Customers requesting additional service will not be notified unless a change in the existing billing arrangement is made. In the event of a change in the existing billing arrangement, the customer will be notified in writing at least thirty (30) days prior to the date when the Exchange Telephone Companies involved in the provision of access service agree to change from one billing arrangement to another. Notification will also include the customer's method of payment.

1. Each Exchange Telephone Company involved shall receive a copy of the order. The Exchange Telephone Company that accepts the order and/or bills the customer is determined as follows:
 - a. FGB, FGC and FGD ordered to an end office - The Exchange Telephone Company where the end office is located will accept the order and bill the customer.
 - b. FGB, FGC and FGD ordered to an access tandem - The Exchange Telephone Company that owns the access tandem will accept the order. The Exchange Telephone Company that owns the end office(s) that subtend the access tandem will bill the customer.
 - c. Directory Assistance - The Exchange Telephone Company where the Directory Assistance bureau is located will accept the order and bill the customer.
2. Upon agreement between the Exchange Telephone Companies involved, a single bill will be rendered to the customer. The Exchange Telephone Company rendering the bill is the Exchange Telephone Company as determined in 1., preceding. There are three single bill alternatives that the Exchange Telephone Company may agree to provide and are described following:

2. GENERAL REGULATIONS

2.4 PAYMENT ARRANGEMENTS AND CREDIT ALLOWANCES

2.4.7 ORDERING, RATING AND BILLING OF ACCESS SERVICES WHERE MORE THAN ONE EXCHANGE TELEPHONE COMPANY IS INVOLVED

B.2. (Cont'd)

There are payment options with Alternatives No. 1 and 2. In the first payment option, the Exchange Telephone Companies can require the customer to remit payment via a single check to the bill rendering Exchange Telephone Company. In the second payment option, the Exchange Telephone Companies can require the customer to remit payment via multiple checks to all of the Exchange Telephone Companies jointly provisioning the Access Service to the customer.

- Alternative No. 1[1]

The Exchange Telephone Company that will render the single bill will separately identify the rates and charges of each Exchange Telephone Company involved. The billing Exchange Telephone Company will maintain and administer in its billing system the applicable rates and charges for all of the involved Exchange Telephone Companies. The Exchange Telephone Companies not rendering the single bill will provide the interpretation and application of their tariffs to the Billing Exchange Telephone Company.

- Alternative No. 2[2]

The Exchange Telephone Company that will render the single bill will receive a prepared bill from each involved Exchange Telephone Company. For Switched Access and/or Directory Assistance Services, the billing Exchange Telephone Company will receive prepared bills without usage data. The billing Exchange Telephone Company will then apply usage data to the bills, calculate the charges and combine all of the bills into one bill. For usage rated services, the billing Exchange Telephone Company and the non-billing Exchange Telephone Company will use the same amount of usage on the bill.

- Alternative No. 3[3]

The Exchange Telephone Company that will render the single bill will include in its rates and charges the costs of each Exchange Telephone Company involved and will bill for the entire access service(s) ordered. For usage rated services, the billing Exchange Telephone Company and the non-billing Exchange Telephone Company will use the same amount of usage on the bill.

[1] Also termed Single Bill - Multiple Tariff

[2] Also termed Single Bill - Pass Through

[3] Also termed Single Bill - Single Tariff

2. GENERAL REGULATIONS

2.4 PAYMENT ARRANGEMENTS AND CREDIT ALLOWANCES

2.4.7 ORDERING, RATING AND BILLING OF ACCESS SERVICES WHERE MORE THAN ONE EXCHANGE TELEPHONE COMPANY IS INVOLVED

B.2. (Cont'd)

The rates and charges for each Exchange Telephone Company are based upon billing percentages. These billing percentages are agreed upon by each Exchange Telephone Company.

The customer will receive from the non-billing Exchange Telephone Company a written agency agreement authorizing payment to the billing Exchange Telephone Company.

3. If the Exchange Telephone Companies involved cannot agree upon a single bill alternative, then each Exchange Telephone Company will render a separate bill to the customer. This billing arrangement is described in 4., following.
4. When the Exchange Telephone Companies involved agree to render separate bills the following terms and conditions apply:
 - a. Each Exchange Telephone Company involved will accept the order from the customer.
 - b. Each Exchange Telephone Company will provide the portion of the Transport element in its operating territory and will bill the charges in accordance with its Access Service tariff. All other appropriate charges in each Exchange Telephone Company's tariff are applicable.
 - c. Each Exchange Telephone Company will render bills for nonrecurring charges as they are incurred. Bills for recurring charges will not be rendered until the service ordered can be provided by all of the Exchange Telephone Companies involved.
 - d. Each Exchange Telephone Company will determine the appropriate Transport by computing the airline mileage between the two ends of the Transport element using the V&H methods as set forth in 6.7.11, following.
 - e. Each Exchange Telephone Company will determine the rate for the airline mileage determined in d., preceding, using the Company's Tariff. Multiply such rate by the Company's billing percentage factor and divide by 100 to obtain the Transport element charges.

2. GENERAL REGULATIONS

2.4 PAYMENT ARRANGEMENTS AND CREDIT ALLOWANCES

2.4.7 ORDERING, RATING AND BILLING OF ACCESS SERVICES WHERE MORE THAN ONE EXCHANGE TELEPHONE COMPANY IS INVOLVED (CONT'D)

- C. The billing percentages will be agreed upon by the Exchange Telephone Companies involved.
- D. When jointly provisioned Access Service is provided between the Company and another Exchange Telephone Company, the appropriate Switched Access recurring rates will be applied based on the type of Switched Transport provided, Tandem-Switched Transport (TST) or Direct-Trunked Transport (DTT).

For Switched Access Service provisioned as TST, the appropriate Switched Access recurring rates will be applied as follows: 1) multiply the Tandem Transmission fixed rate by the minutes of use (MOU) by the billing percentage (BP), 2) multiply the Tandem Transmission per-mile rate by the number of miles, by the MOU by the BP, and 3) all other appropriate Switched Access recurring rate elements at 100 percent, if applicable.

For Switched Access Service provisioned as DTT, the recurring rates will be applied as follows: 1) multiply the monthly Transport Channel fixed rate by the BP, 2) multiply the monthly Transport Channel per-mile rate by the number of miles, by the BP, and 3) all other appropriate Switched Access recurring rate elements at 100 percent, if applicable.

The Exchange Telephone Company that owns the access tandem will assess the appropriate access tandem recurring rates at 100 percent. The Exchange Telephone Company that owns the end office will assess the appropriate end office recurring rates at 100 percent.

- E. When jointly provisioned Switched Access Service is provided and the Company is the intermediate non-terminating carrier, only the recurring Tandem Transmission per-mile rate or DTT per-mile rate for Switched Access Service will apply. The Tandem Transmission per-mile rate or DTT per-mile rate will be determined by multiplying the appropriate rate by the MOU by the number of miles, by the BP. The DTT per-mile rate will be determined by multiplying the appropriate DTT per-mile monthly rate by the number of miles by the BP. If the Company provides the access tandem, all appropriate access tandem recurring rates will apply at 100 percent.
- F. When jointly provisioned Access Service is provided between the Company and another Exchange Telephone Company, or when the Company is the intermediate non-terminating carrier, the appropriate nonrecurring charges shall apply. The BP is not applied to nonrecurring charges.

2. GENERAL REGULATIONS

2.4 PAYMENT ARRANGEMENTS AND CREDIT ALLOWANCES

2.4.7 ORDERING, RATING AND BILLING OF ACCESS SERVICES WHERE MORE THAN ONE EXCHANGE TELEPHONE COMPANY IS INVOLVED (CONT'D)

G. Example - Switched Access provisioned by Direct-Trunked Transport and Tandem-Switched Transport

FEATURE GROUP D ACCESS SERVICE ORDERED

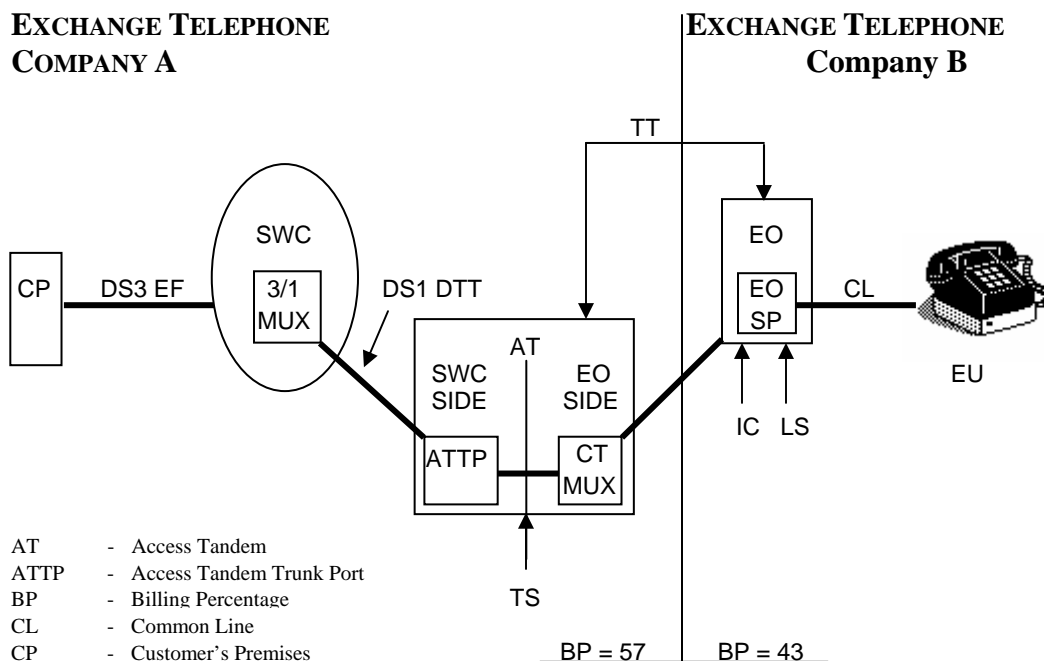

- AT - Access Tandem
- ATTP - Access Tandem Trunk Port
- BP - Billing Percentage
- CL - Common Line
- CP - Customer's Premises
- CT MUX - Common Transport Multiplexing
- DTT - Direct Trunked Transport
- EF - Entrance Facility
- EO - End Office
- EO SP - End Office Shared Port
- EU - End User
- IC - Interconnection Charge
- LS - Local Switching
- MUX - EF Multiplexer
- SWC - Serving Wire Center
- TS - Tandem Switching
- TT - Tandem Transmission

2. GENERAL REGULATIONS

2.4 PAYMENT ARRANGEMENTS AND CREDIT ALLOWANCES

2.4.7 ORDERING, RATING AND BILLING OF ACCESS SERVICES WHERE MORE THAN ONE EXCHANGE TELEPHONE COMPANY IS INVOLVED

G. Example - Switched Access provisioned by Direct-Trunked Transport and Tandem-Switched Transport (Cont'd)

1. Layout

- a. Feature Group D Switched Access is ordered to an end office via DTT and TST.
- b. The premises of ordering customer, the serving wire center (SWC) of that premises, and the access tandem are in operating territory of Exchange Telephone Company A. (A Company exchange).
- c. The customer orders a DS3 Entrance Facility from the customer's premises to the SWC with a 3/1 MUX in the SWC.
- d. The customer orders a DS1 DTT to the AT.
- e. The BP for TT is 57 for Exchange Telephone Company A.
- f. The end office is in the operating territory of Exchange Telephone Company B.
- g. The BP for transport is 43 for Exchange Telephone Company B.

2. GENERAL REGULATIONS

2.4 PAYMENT ARRANGEMENTS AND CREDIT ALLOWANCES

2.4.7 ORDERING, RATING AND BILLING OF ACCESS SERVICES WHERE MORE THAN ONE EXCHANGE TELEPHONE COMPANY IS INVOLVED

G. Example - Switched Access provisioned by Direct-Trunked Transport and Tandem-Switched Transport (Cont'd)

2. Rate elements assessed per Exchange Telephone Company

a. Exchange Telephone Company A

Entrance Facility - 100% of DS3 monthly Entrance Facility rate and 3/1 MUX

DS1 DTT - 100% of DS1 monthly DTT rate

ATTP - 100% of ATTP monthly rate

Tandem Switching - MOU rate X MOU

Common Transport MUX - MOU rate X MOU

Tandem Transmission - Fixed rate X MOU X BP

Tandem Transmission - Per-mile rate X number of miles X MOU X BP

b. Exchange Telephone Company B

Tandem Transport - Transport rate X MOU X BP

Local Switching - MOU rate X MOU

End Office Shared Port - MOU rate X MOU

2. GENERAL REGULATIONS

2.4 PAYMENT ARRANGEMENTS AND CREDIT ALLOWANCES (CONT'D)

2.4.8 ORDERING, RATING AND BILLING OF SWITCHED ACCESS SERVICE PROVIDED IN CONJUNCTION WITH A COMMERCIAL MOBILE RADIO SERVICE PROVIDER

When Switched Access Service is ordered by a customer in conjunction with a Commercial Mobile Radio Service provider, the Company will provide its portion of the Switched Access Service based on the regulations, rates and charges contained in this Tariff, subject to the following rules.

If the Company and the Commercial Mobile Radio Service provider have agreed to jointly provide the Switched Access Service, the Meet Point Billing provisions as set forth in 2.4.7, preceding, shall determine the ordering, rating and billing for access services.

If the Company and the Commercial Mobile Radio Service provider have not agreed to jointly provide the Switched Access Service under the provisions of Meet Point Billing, the Company shall provide the Switched Access Service to the carrier subject to the following rules.

- If the Company provides the Switched Transport and provides end office local switching functions, the customer will be assessed all applicable Switched Access Service rates (i.e., Switched Transport and Local Switching).
- If the Company provides the Switched Transport and does not provide end office local switching functions, the Company will assess all applicable Switched Access Service rates. Local Switching rates will not be assessed by the Company.

The mileage to be used to determine the Switched Transport rate is calculated as set forth in 6.7.11, following.

2. GENERAL REGULATIONS

2.5 CONNECTIONS

2.5.1 GENERAL

Equipment and systems (i.e., terminal equipment, multiline terminating systems and communications systems) may be connected with Switched Access Service furnished by the Company where such connection is made in accordance with the provisions specified in 2.1, preceding.

2.6 DEFINITIONS

Certain terms used herein are defined as follows:

Access Code

The term "Access Code" denotes a uniform seven digit code assigned by the Company to an individual customer. The seven digit code has the form 101XXXX or 950-XXXX.

Access Minutes

The term "Access Minutes" denotes that usage of exchange facilities in intrastate service for the purpose of calculating chargeable usage. On the originating end of an intrastate or foreign call, usage is measured from the time the originating end user's call is delivered by the Company to and acknowledged as received by the customer's facilities connected with the originating exchange. On the terminating end of an intrastate or foreign call, usage is measured from the time the call is received by the end user in the terminating exchange. Timing of usage at both originating and terminating ends of an intrastate call shall terminate when the calling or called party disconnects, whichever event is recognized first in the originating and terminating exchanges, as applicable.

Access Service Group (ASG)

The term "Access Service Group" denotes a group of like access services ordered to an end office or access tandem switch (for Feature Group B, C or D) or to a dial tone office.

2. GENERAL REGULATIONS

2.6 DEFINITIONS (CONT'D)

Access Tandem (AT)

The term "Access Tandem" denotes a Company switching system that provides a concentration and distribution function for originating or terminating traffic between end offices and customers' POT.

Access Transport Parameter (ATP)

The term "Access Transport Parameter" denotes the SS7 Out of Band Signaling parameter which provides the automatic transmission of information from the originating calling location through the Common Channel Signaling Network. Information supplied using ATP may consist of one or more of the following: Called Party Subaddress; Calling Party Subaddress; High and Low Layer Compatibility and Compatibility Checking by the called party's equipment.

Answer/Disconnect Supervision

The term "Answer/Disconnect Supervision" denotes the transmission of the switch trunk equipment supervisory signal (off-hook or on-hook) to the customer's POT as an indication that the called party has answered or disconnected.

Attenuation Distortion

The term "Attenuation Distortion" denotes the difference in loss at specified frequencies relative to the loss at a reference frequency (1004 Hz, unless otherwise specified).

Balance (100 Type) Test Line

The term "Balance (100 Type) Test Line" denotes an arrangement in an end office which provides for balance and noise testing.

2. GENERAL REGULATIONS

2.6 DEFINITIONS (CONT'D)

Bit

The term "Bit" denotes the smallest unit of information in the binary system of notation.

Business Day

The term "Business Day" denotes the times of day that a company is open for business. Generally, in the business community, these are 8:00 or 9:00 A.M. to 5:00 or 6:00 P.M., respectively, with an hour for lunch, Monday through Friday, resulting in a standard forty (40) hour work week. However, Business Day hours for the Company may vary based on Company policy, union contract and location. To determine such hours for an individual Company or Company location, the Company should be contacted at the address shown under the issuing carrier's name listed on Title Page preceding.

Busy Hour Minutes of Capacity (BHMC)

The term "Busy Hour Minutes of Capacity" denotes the customer specified maximum amount of Switched Access Service and/or Directory Assistance Service access minutes the customer expects to be handled in an end office switch during any hour in an 8:00 A.M. to 11:00 P.M. period for the Switched Access Service and/or Directory Assistance Service ordered.

Call

The term "Call" denotes a customer attempt for which the complete address code (e.g., 0-, 911, or 10 digits) is provided to the serving dial tone office.

Calling Party Number (CPN)

The term "Calling Party Number" denotes the SS7 Out of Band Signaling parameter which automatically transmits the calling party's ten-digit telephone number to the customer's premises for calls originating in the LATA.

Carrier or Common Carrier

See "Interexchange Carrier".

2. GENERAL REGULATIONS

2.6 DEFINITIONS (CONT'D)

Carrier Selection Parameter (CSP)

The term "Carrier Selection Parameter" denotes the SS7 Out of Band Signaling parameter which identifies whether the dialing end user accessed the customer's network through a presubscribed line or by dialing the customer's 101XXXX code.

CCS

The term "CCS" denotes a hundred call seconds, which is a standard unit of traffic load that is equal to 100 seconds of usage or capacity of a group of servers (e.g., trunks).

Central Office (CO)

The term "Central Office" denotes a local Company switching system where Telephone Exchange Service customer station loops are terminated for purposes of interconnection to each other and to trunks.

Central Office Prefix

The term "Central Office Prefix" denotes the first three digits (NXX) of the seven digit telephone number assigned to a customer's Telephone Exchange Service when dialed on a local basis.

Centralized Automatic Reporting on Trunks (CAROT) Testing

The term "Centralized Automatic Reporting on Trunks Testing" denotes a type of testing which includes the capacity for measuring operational and transmission parameters.

2. GENERAL REGULATIONS

2.6 DEFINITIONS (CONT'D)

Channel(s)

The term "Channel(s)" denotes an electrical or photonic (in the case of fiber optic-based transmission systems) communications path between two or more points of termination.

Channelize

The term "Channelize" denotes the process of multiplexing-demultiplexing wider bandwidth or higher speed channels into narrower band-width or lower speed channels.

Charge Number (CN)

The term "Charge Number" denotes the SS7 Out of Band Signaling parameter which is equivalent to the ten-digit ANI telephone number.

C-Message Noise

The term "C-Message Noise" denotes the frequency-weighted average noise within an idle voice channel. The frequency weighting, called C-message, is used to account for the variations in 500-type telephone set transducer efficiency and user annoyance, to tones as a function of frequency.

2. GENERAL REGULATIONS

2.6 DEFINITIONS (CONT'D)

C-Notched Noise

The term "C-Notched Noise" denotes the C-message frequency-weighted noise on a voice channel with a holding tone, which is removed at the measuring end through a notch (very narrow band) filter.

Commercial Mobile Radio Service (CMRS) Provider

The term "Commercial Mobile Radio Service Provider" denotes a common carrier as defined by the Federal Communications Commission subject to the Rules set forth in Section 332 of the Communications Act.

Common Channel Signaling Access Capability (CCSAC)

The term "Common Channel Signaling Access Capability" denotes the interconnection between the Company's CCSN and a customer's CCSN.

Common Channel Signaling Network (CCSN)

The term "Common Channel Signaling Network" denotes a specialized digital signaling network separate from the regular message (voice) network which interconnects computerized switching systems and has access to special data bases.

Common Line (CL)

The term "Common Line" denotes a line, trunk or other facility provided under the general and/or local exchange service tariffs of the Company, terminated on a central office switch. A common line-residence is a line or trunk provided under the residence regulations of the Exchange and Network Services Tariff. A common line-business is a line provided under the business regulations of the Exchange and Network Services Catalog.

(T)

Communications System

The term "Communications System" denotes channels and other facilities which are capable of communications between terminal equipment provided by other than the Company.

2. GENERAL REGULATIONS

2.6 DEFINITIONS (CONT'D)

Customer(s)

The term "customer(s)" denotes any individual, partnership, association, joint-stock company, trust, corporation, governmental entity or any other entity which subscribes to the services offered under this Tariff.

Data Transmission (107 Type) Test Line

The term "Data Transmission (107 Type) Test Line" denotes an arrangement which provides for a connection to a signal source which provides test signals for one-way testing of data and voice transmission parameters.

Decibel (dB)

The term "Decibel" denotes a unit of signal power used to express the relationship between two signal powers usually between acoustic, electric or optical signals, equal to ten (10) times the common logarithm of the ratio of two signal powers.

Decibel Milliwatt (dBm)

The term "Decibel Milliwatt" denotes a unit for expression of power level in decibels relative to one milliwatt.

Decibel Reference Noise (dBrn)

The term "Decibel Reference Noise" denotes a unit used to express noise power relative to one picowatt (-90 dBm).

Decibel Reference Noise C-Message Referenced to 0 (dBrnc0)

The term "Decibel Reference Noise C-Message Referenced to 0" denotes noise power in "Decibel Reference Noise C-Message Weighting" referred to or measured at a zero transmission level point.

Decibel Reference Noise C-Message Weighting (dBrnc)

The term "Decibel Reference Noise C-Message Weighting" denotes noise power in dBrn measured with C-Message weighting.

Detail Billing

The term "Detail Billing" denotes the listing of each message and/or rate element for which charges to a customer are due on a bill prepared by the Company.

2. GENERAL REGULATIONS

2.6 DEFINITIONS (CONT'D)

Direct-Trunked Transport (DTT)

The term "Direct-Trunked Transport" denotes the transport between the SWC of the customer's premises and an end office, Company hub or access tandem or between a hub and an end office or access tandem on circuits dedicated to the use of a single customer, without switching at the tandem.

Directory Assistance (DA)

The term "Directory Assistance" denotes the provision of telephone numbers by a Company operator when the operator location is accessed by a customer premises by sending the appropriate signals, i.e., off-hook or 1+NPA+555-1212.

Directory Assistance Location

The term "Directory Assistance Location" denotes a Company office where Company equipment first receives the Directory Assistance call from a customer's end user and selects the first operator position to respond to the Directory Assistance call.

Dual Tone Multifrequency (DTMF) Address Signaling

The term "Dual Tone Multifrequency Address Signaling" denotes a type of signaling that is an Optional Feature of Switched Access Feature Group A. It may be utilized when Feature Group A is being used in the terminating direction (from the POT with the customer to the local exchange end office). An office arranged for Dual Tone Multifrequency Signaling would expect to receive address signals from the customer in the form of Dual Tone Multifrequency signals.

2. GENERAL REGULATIONS

2.6 DEFINITIONS (CONT'D)

Echo Control

The term "Echo Control" denotes the control of reflected signals in a telephone transmission path.

Echo Path Loss (EPL)

The term "Echo Path Loss" denotes the measure of reflected signal at a 4-wire point of termination without regard to the send and receive Transmission Level Point.

Echo Return Loss (ERL)

The term "Echo Return Loss" denotes a frequency-weighted measure of return loss over the middle of the voice band (approximately 560 to 1965 HZ), where talker echo is most annoying.

Effective 2-Wire

The term "Effective 2-Wire" denotes a condition which permits the simultaneous transmission in both directions over a channel, but it is not possible to ensure independent information transmission simultaneously in both directions. Effective 2-wire channels may be terminated with 2-wire or 4-wire interfaces.

Effective 4-Wire

The term "Effective 4-Wire" denotes a condition which permits the simultaneous independent transmission of information in both directions over a channel. The method of implementing Effective 4-Wire transmission is at the discretion of the Company (physical, time-domain, frequency-domain separation or echo cancellation techniques). Effective 4-wire channels may be terminated with a 2-wire interface at the customer's premises. However, when terminated 2-wire, simultaneous independent transmission cannot be supported because the 2-wire interface combines the transmission paths into a single path.

2. GENERAL REGULATIONS

2.6 DEFINITIONS (CONT'D)

800 Data Base Access Service

The term "800 Data Base Access Service" denotes a toll-free originating Trunkside Access Service when the 8XX Service Access Code (i.e., 800, 822, 833, 844, 855, 866, 877 or 888, as available) is used. The term 8XX is used interchangeably with 800 Data Base Access Service throughout this Tariff to describe this service.

8XX Service Provider

The term "8XX Service Provider" denotes a telecommunications company, including Exchange and Interexchange Carriers, that offers 8XX Service to subscribers.

End Office Switch

The term "End Office Switch" denotes a local Company switching system where Telephone Exchange Service customer station loops are terminated for purposes of interconnection to trunks. Included are Remote Switching Modules and Remote Switching Systems served by a host office in a different wire center.

End User (EU)

The term "End user" denotes any customer of an intrastate telecommunications service that is not a carrier, except that a carrier, other than a telephone company, shall be deemed to be an "end user" when such carrier uses a telecommunications service for administrative purposes; and a person or entity that offers telecommunications services exclusively as a reseller shall be deemed to be an "end user" if all resale transmissions offered by such reseller originate or terminate on the premises of such reseller.

End User-Point of Termination (EU-POT)

The term "End User-Point of Termination" denotes the network channel interface that is at the terminating end of the overall circuit is referred to as the end user-POT.

2. GENERAL REGULATIONS

2.6 DEFINITIONS (CONT'D)

Entrance Facility (EF)

The term "Entrance Facility" denotes the dedicated Switched Access transport facility from the customer's premises or point of demarcation to the Company SWC.

Entry Switch

See "First Point of Switching".

Envelope Delay Distortion (EDD)

The term "Envelope Delay Distortion" denotes a measure of the linearity of the phase versus frequency of a channel.

Equal Level Echo Path Loss (ELEPL)

The term "Equal Level Echo Path Loss" (ELEPL) denotes the measure of Echo Path Loss (EPL) at a 4-wire interface which is corrected by the difference between the send and receive Transmission Level Point (TLP).
[ELEPL = EPL - TLP (send) + TLP (receive)].

Exchange

The term "Exchange" denotes a unit generally smaller than a Local Access and Transport Area (LATA), established by the Company for the administration of communications service in a specified area which usually embraces a city, town or village and its environs. It consists of one or more central offices together with the associated facilities used in furnishing communications service within that area. One or more designated exchanges comprise a given LATA.